

Bulletin 3-2008

DMV – ROTAX MAX Challenge 2008

(Änderungen *rot und kursiv* gekennzeichnet)

zu Art.Nr. 9.4 der RMC Technical Regulations, Version 10.01.08:

Technical Specification (outside the engine seal) for ROTAX kart engine 125 MAX DD2 (24 kW)

Ignition system § 10.5

The pick up must be marked with the numbers 029600-0710, followed by a variable production code in the 2nd line.

Das Hinzufügen einer oder mehrerer Dichtungen (1) mit der Original-ROTAX Teile-Nr. 431500 und/oder einer Zwischenhülse (2) ist erlaubt. Die Hülse muss aus einem hitzbeständigen Material (z.B. Teflon) bestehen und so dimensioniert sein, dass sie exakt zwischen Gehäusebohrung und Geber passt.

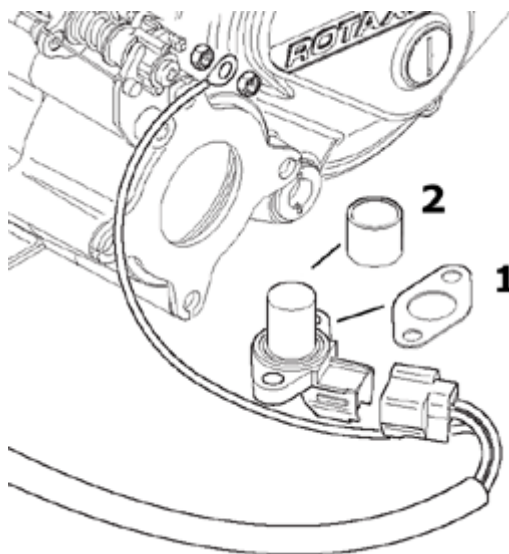

HINT: In case of doubt an easy check is to place a steel ball (3-5 mm in diameter) on the pickup (engine side), the steel ball must stay in the center of the pickup surface.

Frankfurt, den 09.04.2008

Michael Weichert
DMV-Sportabteilung

Rödermark, den 07.04.2008

Peter Kessler
RMC-Präsident

DEUTSCHER MOTORSPORT VERBAND E.V.
DMV-Geschäftsstelle
im DSB-Haus des Sports II
Otto-Fleck-Schneise 12
60528 Frankfurt am Main
Telefon: 0 69 / 69 50 02-0
Telefax: 0 69 / 69 50 02-20
E-Mail: dmv@dmv-motorsport.de
www.dmv-motorsport.de
Bankverbindungen:
Frankfurter Volksbank
BLZ 501 900 00
Konto-Nr. 30990-7
Frankfurter Sparkasse 1822
BLZ 500 502 01
Konto-Nr. 368 555
Postbank
BLZ 500 100 60
Konto-Nr. 18 907-604
St. Nr. 4525009941

Offizielle Förderer des Deutschen Motorsport Verbandes e.V.

