



APPROVED



ROTAX MOJO MAX CHALLENGE

Regulations 2008

Bulletin 11 09.06.2008 (changes underlined)

Technical regulations

125 MAX / 125 Junior MAX

Radiator	18.1	Single aluminium radiator as shown in illustration
	18.2	Cooling area: Height = 290 mm, width = 133 mm
	18.3	Thickness of radiator = 32 mm
	18.4	Place of fixing the radiator is on right side of engine.
	18.5	Radiator must be mounted with all components as shown in the illustration either like version 1 or like version 2. <u>At version 2 there is 2 legal options to mount the radiator to the retaining plate (see drawing for details)</u>
	18.6	No additional cooling device is allowed. Tape applied around the radiator is the only allowed air flow control. Tape may not be removed from the radiator during operation on the track. All other means of air flow control through the radiator are prohibited.
	18.7	The removal of the thermostat from the cylinder head cover is an acceptable configuration.

Version 1

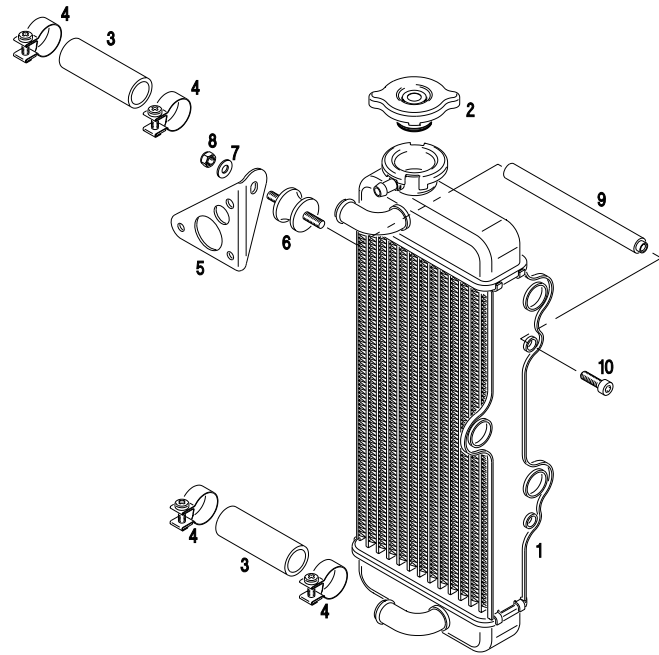

Illustration 5

Version 2

